

MAGNESIUM

2021

RACING WHEEL RIMS for KARTS

www.tecnokart.com



40 Standard series

Magnesium

1

Cod. 580/096

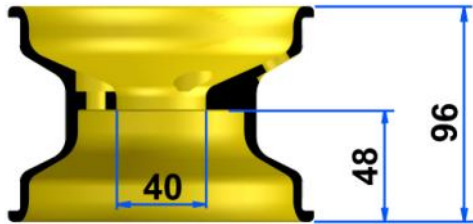

Bead-retainer Option

Viti di sicurezza Opzione

2

Cod. 580/114

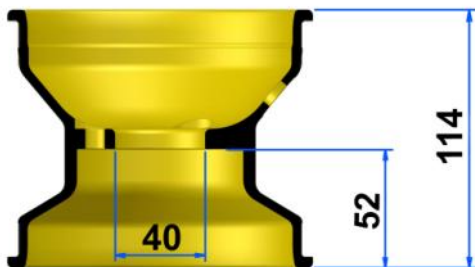

Bead-retainer Option

Viti di sicurezza Opzione

3

Cod. 580/120

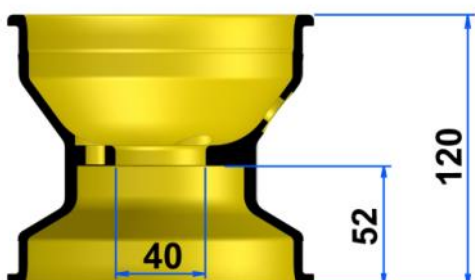

Bead-retainer Option

Viti di sicurezza Opzione

40 Standard series

Magnesium

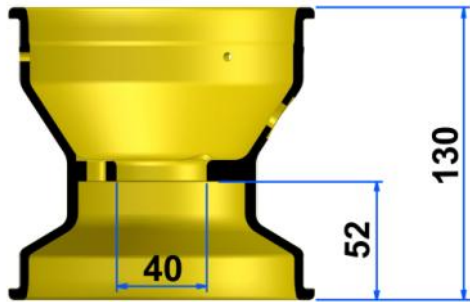

Cod. 580/130

4

Bead-retainer Included

Viti di sicurezza Includere

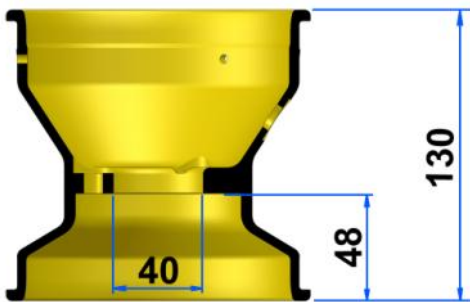

Cod. 580/130D

5

Bead-retainer Included

Viti di sicurezza Includere

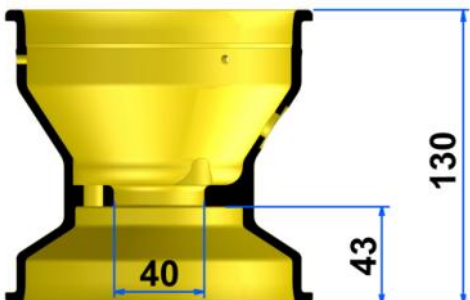

Cod. 580/130B

6

Bead-retainer Included

Viti di sicurezza Includere

40 Standard series Magnesium

7

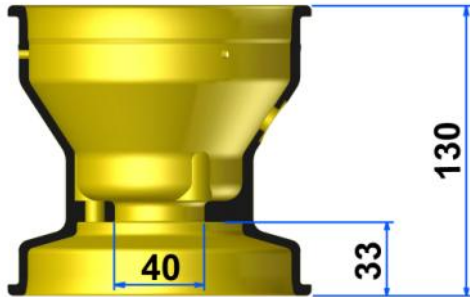

Cod. 580/130C

Bead-retainer Included

Viti di sicurezza Incluse

8

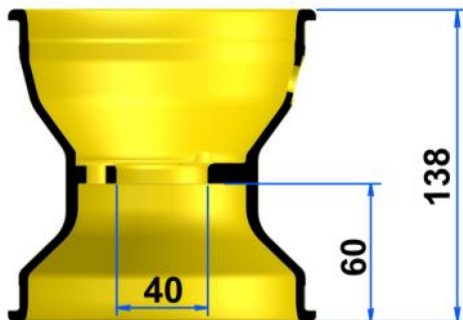

Cod. 580/138

Bead-retainer Option

Viti di sicurezza Opzione

9

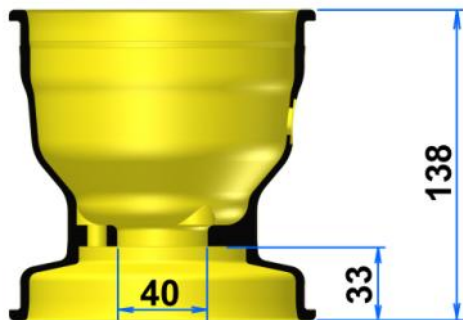

Cod. 580/138C

Bead-retainer Option

Viti di sicurezza Opzione

40 Standard series Magnesium

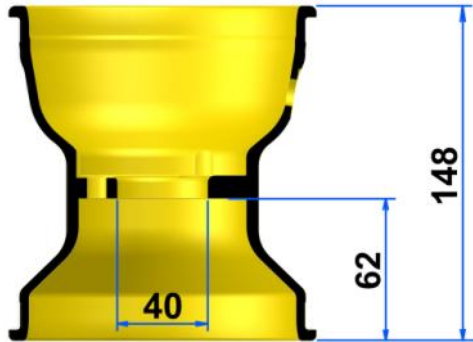

10

Cod. 580/148

Bead-retainer Option

Viti di sicurezza Opzione

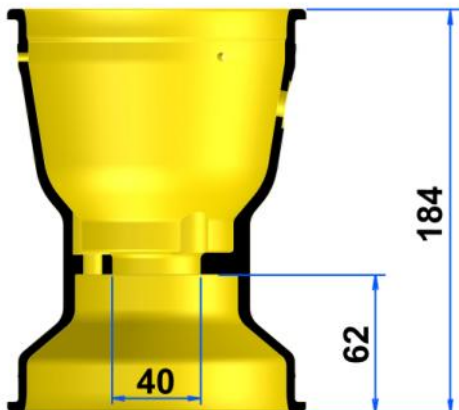

11

Cod. 580/184

Bead-retainer Included

Viti di sicurezza Include

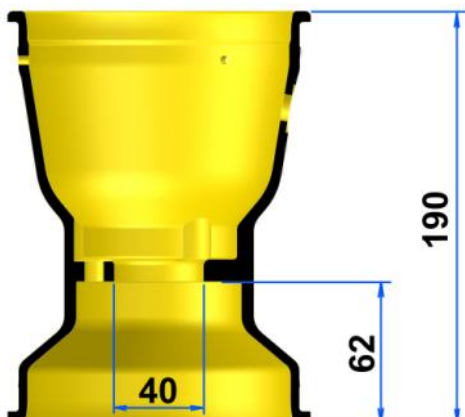

12

Cod. 580/190S

With milled internal design

Modello con asole interne

Bead-retainer Included

Viti di sicurezza Include

40 Standard series Magnesium

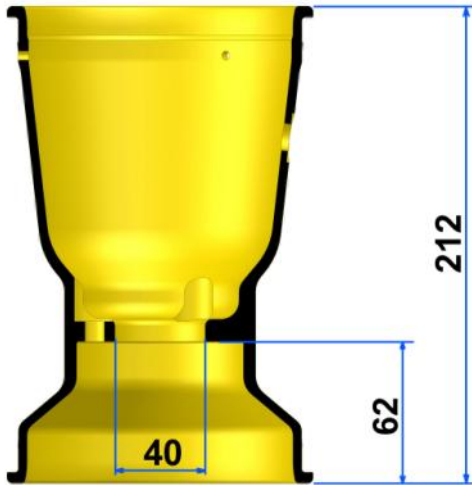

Cod. 580/212

13

Bead-retainer Option

Viti di sicurezza Opzione

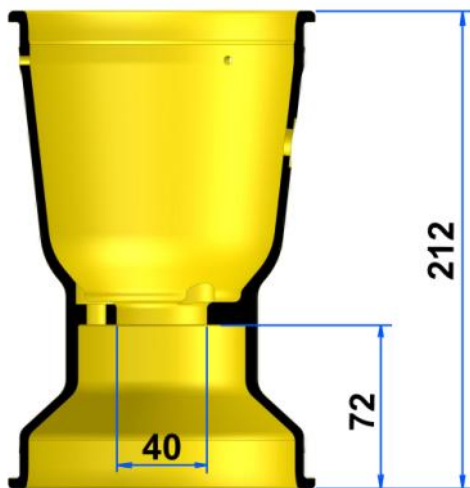

Cod. 580/212D

14

Bead-retainer Included

Viti di sicurezza Incluse

40 R series
Magnesium

FORGED

15

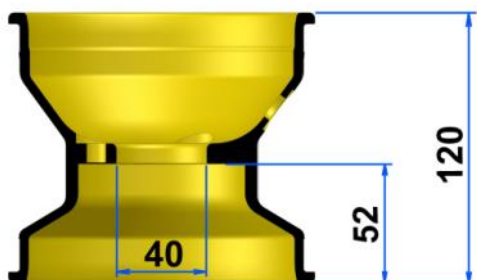

Cod. 580/120R

Bead-retainer Option

Viti di sicurezza Opzione

16

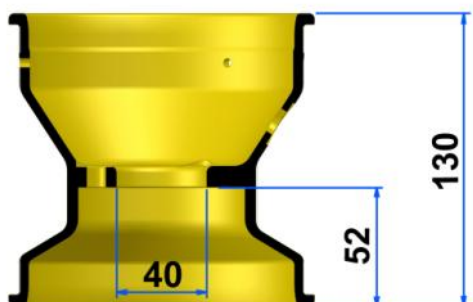

Cod. 580/130R

Bead-retainer Included

Viti di sicurezza Include

17

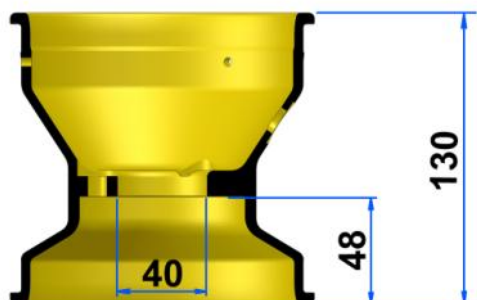

Cod. 580/130DR

Bead-retainer Included

Viti di sicurezza Include

40 R series Magnesium

FORGED

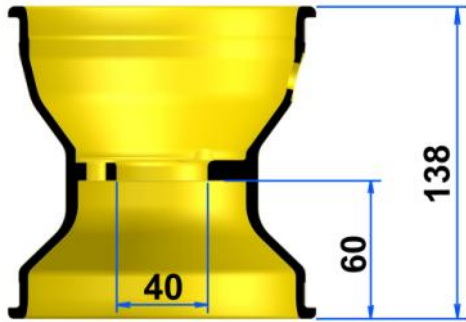

Cod. 580/138R

18

Bead-retainer Included

Viti di sicurezza Incluse

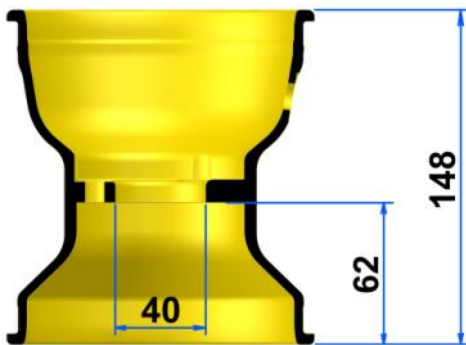

Cod. 580/148R

19

Bead-retainer Included

Viti di sicurezza Incluso

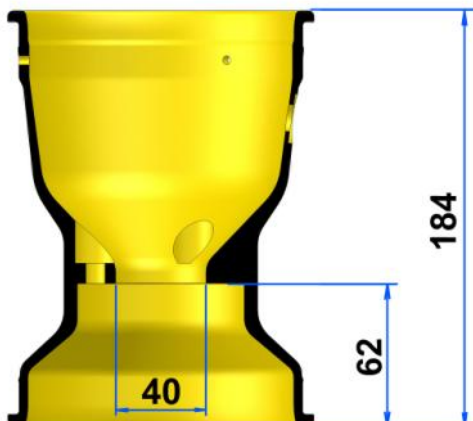

Cod. 580/184R

20

SPECIAL for RAIN

SPECIALE per PIOGGIA

Bead-retainer Included

Viti di sicurezza Incluse

40 R series
Magnesium

FORGED

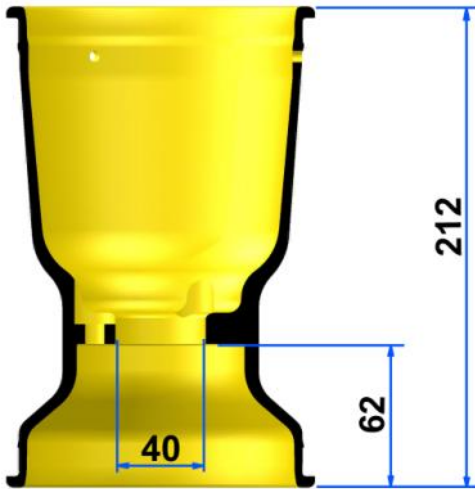

21

Cod. 580/212R

Bead-retainer Included

Viti di sicurezza Incluso

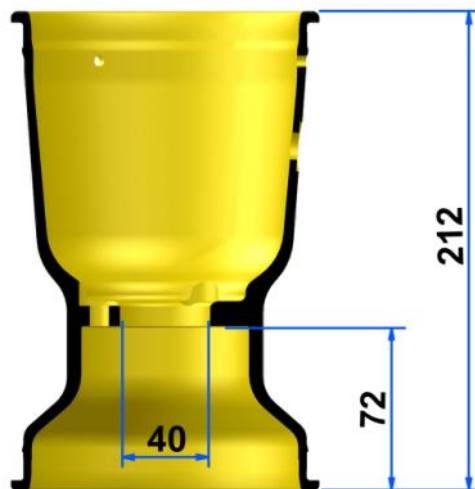

22

Cod. 580/212DR

Bead-retainer Included

Viti di sicurezza Inclusive

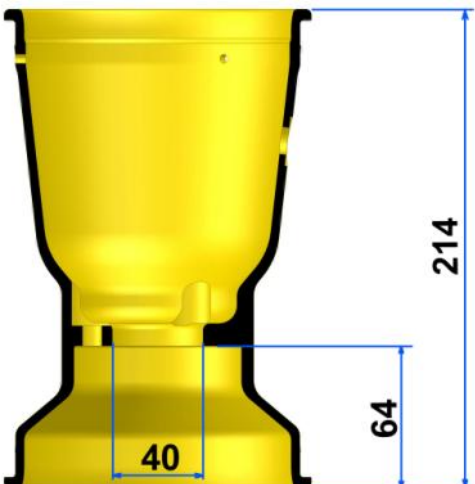

23

Cod. 580/214R

Bead-retainer Included

Viti di sicurezza Inclusive

Monoblock Magnesium

24



Cod. 582/120

Bead-retainer Option

Viti di sicurezza Opzione

25



Cod. 582/126

Front Wheel Vintage

Bead-retainer Option

Viti di sicurezza Opzione

Rear Wheel Vintage

26

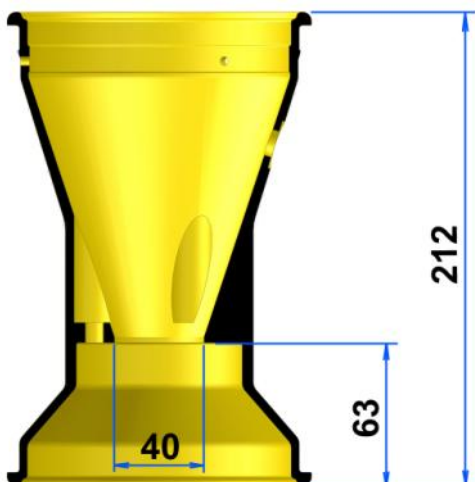

Cod. 580/212C

Bead-retainer Option

Viti di sicurezza Opzione

ST-50 series Magnesium

27

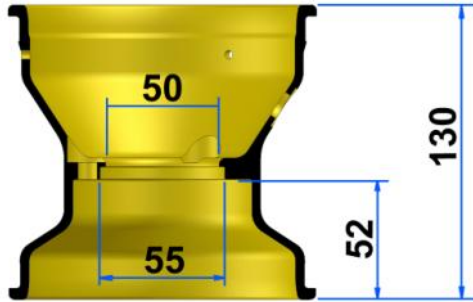

Cod. 581/130

Required ST50 Hubs

Richiede Mozzi ST50

Bead-retainer Included

Viti di sicurezza Incluse

28

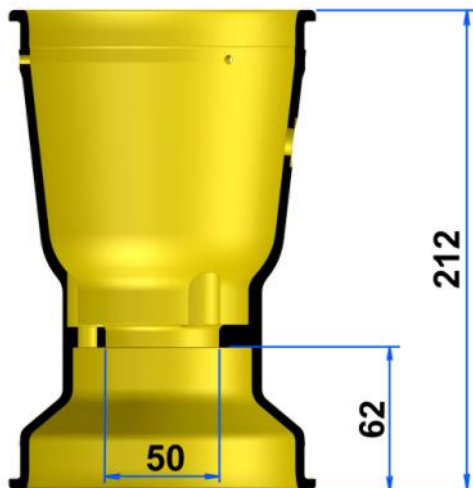

Cod. 581/212

Required ST50 Hubs

Richiede Mozzi ST50

Bead-retainer Included

Viti di sicurezza Incluse

ST-50 R series Magnesium

FORGED

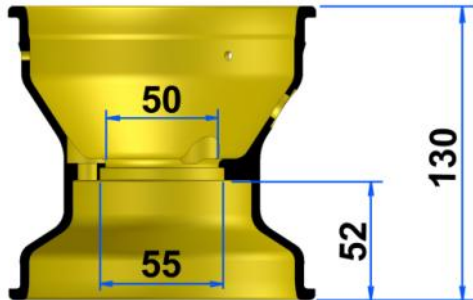

29

Cod. 581/130R

Required ST50 Hubs

Richiede Mozzi ST50

Bead-retainer Included

Viti di sicurezza Include

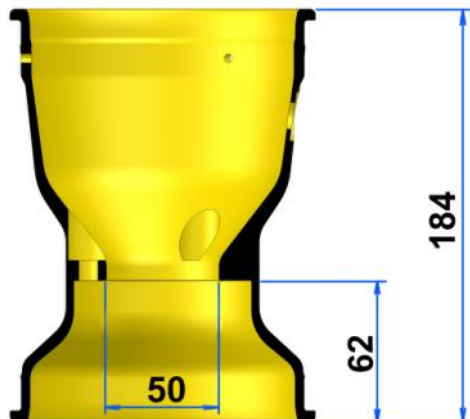

30

Cod. 581/184R

SPECIAL for RAIN

SPECIALE per PIOGGIA

Required ST50 Hubs

Richiede Mozzi ST50

Bead-retainer Included

Viti di sicurezza Include

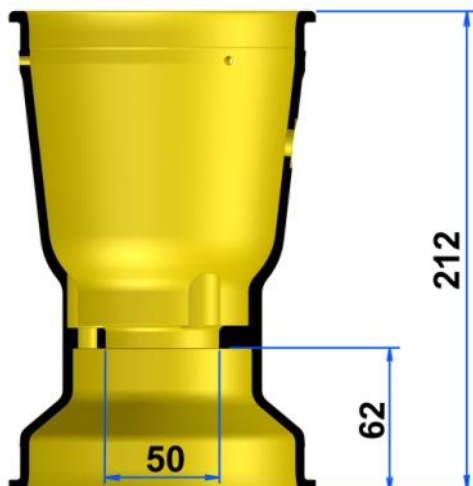

31

Cod. 581/212R

Required ST50 Hubs

Richiede Mozzi ST50

Bead-retainer Included

Viti di sicurezza Include



A

Cod. 580/005K

Kit Bead Retainer Screws and O-rings (12pcs)

Kit Viti di Sicurezza e OR (12pz)



B

Cod. 580/003

Tubeless Valve

Valvola Tubeless

Magnesium

Hubs for ST-50 Wheels

Mozzi per Cerchi ST-50

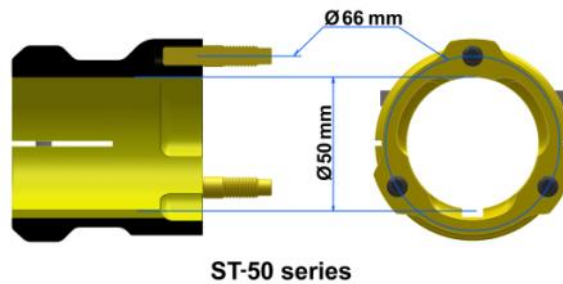

C

Cod. 572/055

Ø25 x 90mm

Front hub with bearings
Mozzo ant. con cuscinetti



D

Cod. 572/052

Ø50 x 76mm

Front hub
Mozzo anteriore



E

Cod. 570/052

Ø50 x 88mm

Rear hub
Mozzo posteriore



F

Cod. 570/053

Ø50 x 110mm

Rear hub
Mozzo posteriore

6 inches Magnesium Wheels

Tubeless Valve Included Valvola Tubeless Inclusa
Bead-retainer Included Viti di sicurezza Incluse

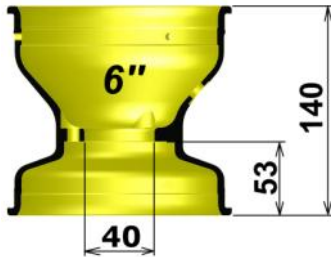

Cod. 584/140

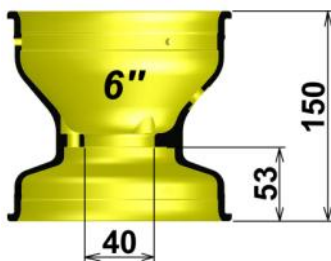

Cod. 584/150

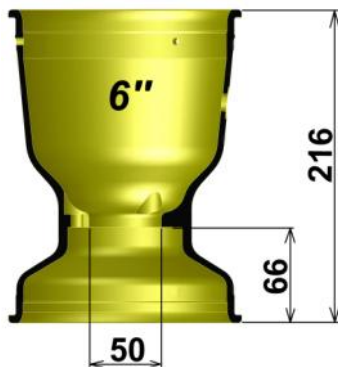

Cod. 584/216

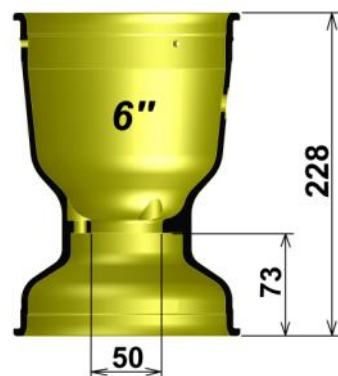

Cod. 584/228



Rear Hub
Mozzo posteriore

ST50 Ø40 x 88mm
Magnesium
Magnesio

Rear wheels are compatible with 66mm pitch circle diameter hubs.

I cerchi posteriore sono compatibile con i Mozzi ST50

FRONT HUB

MOZZO ANTERIORE



G

MAGNESIUM

572/370	FRONT HUB Mg Ø25 L=70 complete	MOZZO Ant. Mg Ø25 L=70 completo
572/390	FRONT HUB Mg Ø25 L=90 complete	MOZZO Ant. Mg Ø25 L=90 completo

H

MAGNESIUM



572/045	FRONT HUB Mg Ø17 L=45 complete	MOZZO Ant. Mg Ø17 L=45 completo
572/060	FRONT HUB Mg Ø17 L=60 complete	MOZZO Ant. Mg Ø17 L=60 completo
572/075	FRONT HUB Mg Ø17 L=75 complete	MOZZO Ant. Mg Ø17 L=75 completo
572/090	FRONT HUB Mg Ø17 L=90 complete	MOZZO Ant. Mg Ø17 L=90 completo

I

ALUMINIUM



572/250	FRONT HUB Al Ø17 L=45 complete	MOZZO Ant. Al Ø17 L=45 completo
572/260	FRONT HUB Al Ø17 L=60 complete	MOZZO Ant. Al Ø17 L=60 completo
572/275	FRONT HUB Al Ø17 L=75 complete	MOZZO Ant. Al Ø17 L=75 completo
572/290	FRONT HUB Al Ø17 L=90 complete	MOZZO Ant. Al Ø17 L=90 completo
572/205	FRONT HUB Al Ø17 L=105 complete	MOZZO Ant. Al Ø17 L=105 completo



J

MAGNESIUM

572/576	FRONT HUB Mg Ø50 L=76	MOZZO Ant. Mg Ø50 L=76
---------	-----------------------	------------------------

ALL REAR HUBS INCLUDE 3 STUD BOLTS M8x43

TUTTI I MOZZI POST. INCLUDONO 3 PRIGIONIERI M8x43

REAR HUB

MOZZO POSTERIORE

K

MAGNESIUM



570/124	REAR HUB Mg Ø50 L=77	MOZZO Post. Mg Ø50 L=77
570/121	REAR HUB Mg Ø50 L=88	MOZZO Post. Mg Ø50 L=88
570/122	REAR HUB Mg Ø50 L=110	MOZZO Post. Mg Ø50 L=110
570/013	REAR HUB Mg Ø40 L=88	MOZZO Post. Mg Ø40 L=88

L

MAGNESIUM



570/001	REAR HUB Mg Ø30 L=50	MOZZO Post. Mg Ø30 L=50
570/002	REAR HUB Mg Ø30 L=75	MOZZO Post. Mg Ø30 L=75
570/003	REAR HUB Mg Ø30 L=98	MOZZO Post. Mg Ø30 L=98

M

MAGNESIUM AND ALUMINIUM HUBS



470/630	REAR HUB Al Ø30 L=40 - DISC CARRIER for MINI	MOZZO Post. Al Ø30 L=40 - PORTADISCO MINI
470/625	REAR HUB Mg Ø25 L=40 - DISC CARRIER for PUFFO	MOZZO Post. Mg Ø25 L=40 - PORTADISCO PUFFO
570/125	REAR HUB Mg Ø25 L=50	MOZZO Post. Mg Ø25 L=50
570/130	REAR HUB Mg Ø30 L=50	MOZZO Post. Mg Ø30 L=50

N

ALUMINIUM



571/005	REAR HUB Al Ø30 L=50	MOZZO Post. Al Ø30 L=50
571/004	REAR HUB Al Ø30 L=88	MOZZO Post. Al Ø30 L=88

ALL REAR HUBS INCLUDE 3 STUD BOLTS M8x43

TUTTI I MOZZI POST. INCLUDONO 3 PRIGIONIERI M8x43

How to Inflate a tire

- Loosen the bead retainer screws. (photo 1)
- Remove the valve core for added air flow. (photo 2)
- Use soap and water to help the tire bead seat.

WARNING

- Never hold the air hose head in hand, when inflating a tire. (photo 3, 4)
- Avoid staying at both sides of the rim, when inflating a tire.
- Do not exceed 4 bar, when seating a tire on the rim.



photo 1

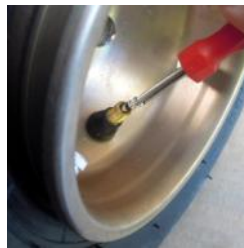

photo 2



photo 3



photo 4

Montaggio del pneumatico

- Allentare le viti di sicurezza. (photo 1)
- Rimuovere la valvola per un maggior passaggio dell'aria. (photo 2)
- Mettere del sapone sulla sede del pneumatico che è a contatto con il cerchio.

AVVERTENZA

- Mai tenere le mani nel cerchio, quando si tallona il pneumatico. (photo 3, 4)
- Non sostare davanti ai lati del cerchio, quando si tallona il pneumatico.
- Non superare 4 bar, quando si tallona il pneumatico sul cerchio.

Customer Price List / Listino Prezzi al Pubblico

FRONT HUBS

MOZZI ANTERIORI

FIG.	COD.	DESCRIPTION	DESCRIZIONE	QTY.	€
G	572/370	FRONT HUB Mg Ø25 L=70 complete	MOZZO Ant. Mg Ø25 L=70 completo	1	
	572/390	FRONT HUB Mg Ø25 L=90 complete	MOZZO Ant. Mg Ø25 L=90 completo	1	
H	572/045	FRONT HUB Mg Ø17 L=45 complete	MOZZO Ant. Mg Ø17 L=45 completo	1	
	572/060	FRONT HUB Mg Ø17 L=60 complete	MOZZO Ant. Mg Ø17 L=60 completo	1	
	572/075	FRONT HUB Mg Ø17 L=75 complete	MOZZO Ant. Mg Ø17 L=75 completo	1	
	572/090	FRONT HUB Mg Ø17 L=90 complete	MOZZO Ant. Mg Ø17 L=90 completo	1	
I	572/250	FRONT HUB Al Ø17 L=45 complete	MOZZO Ant. Al Ø17 L=45 completo	1	
	572/260	FRONT HUB Al Ø17 L=60 complete	MOZZO Ant. Al Ø17 L=60 completo	1	
	572/275	FRONT HUB Al Ø17 L=75 complete	MOZZO Ant. Al Ø17 L=75 completo	1	
	572/290	FRONT HUB Al Ø17 L=90 complete	MOZZO Ant. Al Ø17 L=90 completo	1	
	572/205	FRONT HUB Al Ø17 L=105 complete	MOZZO Ant. Al Ø17 L=105 completo	1	
J	572/576	FRONT HUB Mg Ø50 L=76	MOZZO Ant. Mg Ø50 L=76	1	
C	572/055	FRONT HUB ST50 Ø25x90	MOZZO ANTERIORE ST50 Ø50x90	1	
D	572/052	FRONT HUB ST50 Ø50x76	MOZZO ANTERIORE ST50 Ø50x76	1	

ALL REAR HUBS INCLUDE 3 STUD BOLTS M8x43

TUTTI I MOZZI POST. INCLUDONO 3 PRIGIONIERI M8x43

The prices and the specs are subject to change without notice.
I prezzi e le specifiche potranno essere modificati senza preavviso.

The prices indicated at this list exclude all applicable taxes.
I prezzi indicati in questa lista sono tasse escluse.

Customer Price List / Listino Prezzi al Pubblico

REAR HUBS

MOZZI POSTERIORI

FIG.	COD.	DESCRIPTION	DESCRIZIONE	QTY.	€
K	570/124	REAR HUB Mg Ø50 L=77	MOZZO Post. Mg Ø50 L=77	1	
	570/121	REAR HUB Mg Ø50 L=88	MOZZO Post. Mg Ø50 L=88	1	
	570/122	REAR HUB Mg Ø50 L=110	MOZZO Post. Mg Ø50 L=110	1	
	570/013	REAR HUB Mg Ø40 L=88	MOZZO Post. Mg Ø40 L=88	1	
L	570/001	REAR HUB Mg Ø30 L=50	MOZZO Post. Mg Ø30 L=50	1	
	570/002	REAR HUB Mg Ø30 L=75	MOZZO Post. Mg Ø30 L=75	1	
	570/003	REAR HUB Mg Ø30 L=98	MOZZO Post. Mg Ø30 L=98	1	
M	470/630	REAR HUB Al Ø30 L=40 - DISC CARRIER for MINI	MOZZO Post. Al Ø30 L=40 - PORTADISCO MINI	1	
	470/625	REAR HUB Mg Ø25 L=40 - DISC CARRIER for PUFFO	MOZZO Post. Mg Ø25 L=40 - PORTADISCO PUFFO	1	
	570/125	REAR HUB Mg Ø25 L=50	MOZZO Post. Mg Ø25 L=50	1	
	570/130	REAR HUB Mg Ø30 L=50	MOZZO Post. Mg Ø30 L=50	1	
N	571/005	REAR HUB Al Ø30 L=50	MOZZO Post. Al Ø30 L=50	1	
	571/004	REAR HUB Al Ø30 L=88	MOZZO Post. Al Ø30 L=88	1	
E	570/052	REAR HUB ST50 Ø50x88	MOZZO POSTERIORE ST50 Ø50x88	1	
F	570/053	REAR HUB ST50 Ø50x110	MOZZO POSTERIORE ST50 Ø50x110	1	

ALL REAR HUBS INCLUDE 3 STUD BOLTS M8x43

TUTTI I MOZZI POST. INCLUDONO 3 PRIGIONIERI M8x43

The prices and the specs are subject to change without notice.
I prezzi e le specifiche potranno essere modificati senza preavviso.

The prices indicated at this list exclude all applicable taxes.
I prezzi indicati in questa lista sono tasse escluse.